

SPARKLING CLEAR ALGAE-FREE WATER FOR POOLS & SPAS



Triangular Wave Technologies Advanced Methods For Pool Management And Control



- **Chemical-Free (TWT[®]) Patented Deposit Control**
- **IonGuard (ionization) Disinfection**
- **Ultra-Violet (UV) Purification**

Easy on the Eyes

Gain peace of mind with TWT Enhanced Control Pool Management Systems, the chemical-free, safe and easy way to enjoy your pool and spa season! Your backyard or indoor pool is a place for relaxation. Everyone wants to avoid problems with their pool, and also with the effects of handling, storing, and swimming in harsh chemicals and treated water. The good news is TWT has the solution for both!

Super Sparkling Water

The Enhanced Control Pool Management System works with your existing pool filter and pump systems to control deposits and purify the water, killing and removing harmful bacteria and algae, and preventing corrosion and

deterioration of your pipes and equipment. Reduce your chemical treatments and maintenance efforts by 80% or more, and make your swimming experience safe, fun, and environmentally friendly.

- *Reduce the need for chlorine and get the same results with TWT chemical-free treatment & conditioning systems*
- *Protect the investment in your pool/spa from the harsh effects of chemicals*
- *Enhance water quality, and improve operating efficiency and equipment life cycle.*



Triangular Wave Technologies Solves These Common Problems With Its Deposit Control & IonGuard Purification and/or Ultra-Violet Systems

COMMON PROBLEMS WITH CONVENTIONAL POOL TREATMENT SYSTEMS

- *Algae and bacteria growth, corrosion, scale and bio-film accumulation in water lines and equipment*
- *Deterioration of water lines and equipment from harsh chemicals*
- *High electrical costs from operating inefficient (heating and pumping equipment)*
- *Use of chemicals (chlorine, bromine, etc.)*
- *Labor costs for cleaning, maintenance, and supervision*
- *Complaints related to harsh chemical odors (usually from chlorine) and resulting irritation of the eyes and mucous membrane, as well as bleached swim wear, hair discoloration, etc.*

Each of these problems can be addressed with TWT's Enhanced Control Pool Management Systems, consisting of TWT Deposit Controllers, Reaction Chambers, and IonGuard Purification Subsystems with Copper/Silver Electrodes and/or Ultra-Violet. These highly effective systems and methods of maintenance work in three ways:

- *The deposit control microprocessor with the attached reaction chamber produces an electromagnetic field through which the re-circulated pool water flows for treatment*
- *The IonGuard system provides disinfection of the water*
- *The Ultra-Violet provides purification*

The TWT Enhanced Control Pool Management System offers pool maintenance owners & firms an opportunity to reduce their material and labor costs, lessen the storage and handling of the chemicals now used. *In combination with the pool's filter and pump systems*, the complete TWT system augments the chemical treatment normally applied by controlling the habitats where bacteria, algae, and bio-film grow. When these habitats are uniformly controlled and/or eliminated, the pool maintainer can reduce the usage and handling of harsh chemicals, and use less labor in the performance of his (contracted) services if provided.

ALGAE AND BACTERIA GROWTH

Bacteria and algae must attach to something (such as pipes, equipment or pool walls) to feed and reproduce.



The triangular wave electromagnetic field

generated by the patented TWT Deposit Controller prevents this attachment by keeping bacteria and algae dispersed in the water. With the contaminant's "in solution", the IonGuard Purification Unit and/or UV goes to work, killing the algae and bacteria by producing copper and silver ions, a proven and safe method for control. This "chemical-free" method of treatment produces no negative effects on people, no damage to equipment, and no pollution of the environment. It is the safest known deposit control and purification method for controlling algae and bacteria, and eliminates side-effects.

CORROSION, SCALE AND BIOFILM ACCUMULATION IN LINES AND EQUIPMENT

The TWT Enhanced Control Pool Management System attacks this problem by causing contaminant's to repel from each other and from the surfaces of pipes and equipment, with its enhanced surface charge on particles in the water. Bio-corrosion is prevented because biofilm, its home, is never given the opportunity to form on the surfaces.

DETERIORATION OF LINES AND EQUIPMENT FROM HARSH CHEMICALS

Many of the chemicals used in water treatment (chlorine especially) cause PVC pipes to become brittle, resulting in the need for extensive maintenance and/or replacement. These chemicals also reduce the useful life of the rest of the equipment in the system.

HIGH ELECTRICAL COSTS (HEATING AND PUMPING EQUIPMENT)

The electricity required for heating pools and pumping water can be a considerable expense. As the TWT Enhanced Control Pool Management System reduces scaling and corrosion in the heating elements, the elements work more efficiently, reducing electrical costs for heating the water. Similarly, many pool, spa and decorative water feature operators feel the need to operate their pumps continuously to enhance the filtration process and produce clear water. As the TWT Enhanced Control Pool Management System eliminates clouding contaminant's, the use of the pumps to obtain satisfactory levels of clarity can be greatly reduced, usually to 1/3 or less of a routine operation. Additionally, as the corrosion and scale are eliminated, the pumps operate more efficiently, resulting in reduced electricity costs, as with the heating elements.

CHEMICAL USE (CHLORINE, ETC.)

While necessary, chlorine treatment of swimming pools is not only costly, but also objectionable in terms of practical,

aesthetic and health considerations. As a chemical, chlorine has a corrosive effect on pool lines and equipment, resulting in periodic replacement. Although chlorine has been the accepted standard for treating water (and in fact a minimum residual level of chlorine is required in commercial pools), smaller amounts will create other problems. Alternatively, the TWT Enhanced Control Pool Management System will enable desired reduction in chemical treatment, while maintaining appropriate levels of purification.

LABOR COSTS FOR CLEANING, MAINTENANCE AND SUPERVISION

The TWT Enhanced Control Pool Management System allows routine pool maintenance to be accomplished more quickly and efficiently, allowing the maintenance company to service more pools and accounts with existing staff levels. The TWT units are maintenance-free. The IonGuard unit requires only routine inspection and periodic changes of the electrodes (usually annually depending upon usage). However, in contrast to the frequent tasks of traditional pool maintenance, the tasks associated with the TWT systems are minimal. This reduced maintenance permits reduced labor costs per pool.

COMPLAINTS RELATED TO ODOR (CHLORINE, FISHY SMELL, ETC.)

The chemical odor and other unpleasant odors are removed. Perhaps more significant than the odor control benefit, the treated water produced by the swimming pool systems (although not recommended for drinking) is actually rendered to an acceptable level for drinking, in case of accidental ingestion. Finally, the cost savings on chemicals, electricity, labor, increased life cycles of equipment and other uses is sufficient enough to pay for the system in 18 months or less. In contrast to current pool maintenance programs, the system will result in significant cost savings. More importantly, it will provide swimmers with a clean, odorless and healthier swimming environment.

Clearly, in comparison to traditional pool maintenance programs, the TWT Enhanced Control Pool Management System will result in significant cost savings and increased profits.



HARD WATER PROBLEMS SOLVED EASILY!
Your Simple and Safe Solution!

THERE ARE THREE BASIC CAUSES OF WATER/FLUID RELATED PROBLEMS

SCALE

- Problems:
- *Loss of heat transfer efficiency*
 - *Flow restriction in pipes and frozen valves*
 - *Back pressure increases energy needed to pump*
 - *Reduced reaction vessel capacity*
 - *Localized corrosion*
 - *Visible surface scale objectionable*

ADVERSE WATER CHEMISTRY

- Problem:
- *General corrosion*

Biofilm

- Problems:
- *Loss of heat transfer efficiency*
 - *Biocorrosion (both general and local)*
 - *Sludge*
 - *Disease and odors*
 - *Bacteria, Algae, Fungus, etc.*

THE END RESULTS OF WATER PROBLEMS

- *Wasted water*
- *Ruined equipment*
- *High energy costs*
- *Productivity losses*
- *Product contamination or quality problems*
- *Disease and odor in the cooling water environment*

MATERIALS THAT DEPOSIT ON EQUIPMENT AND CAUSE WATER/FLUID PROBLEMS

Materials may be animal, vegetable, mineral, or corrosive water chemistry. The sources of the materials include: pollution; wind borne dirt, bacteria, and algae; chemical additives; and process components themselves. Some of the materials can grow; such as bacteria, algae, fungus, etc

TREATMENT

The bottom line is that if the problem causing materials are controlled, then 85% to 90% of the problems are eliminated. Treatment options include removal and control.

- *Removal involves physical or chemical cleaning; filtration; ion exchange; softening; demineralization, reverse osmosis.*
- *Control involves adding chemicals or ozone, or electronically conditioning the water.*

BENEFITS OF THE PATENTED TRIANGULAR WAVE SYSTEM

Prevents Scale Build-up Throughout the Fluid System

Scale particles and colloids in the water receive a treatment that causes them to remain suspended and away from the surfaces of the equipment. The effect of the Triangular Wave Systems lasts for many days; allowing the treatment to be continuously effective throughout the water system, when in operation.

Saves Energy

Energy savings of 2% to 30% are possible, because without scale pipe surfaces are less rough, pumps run more efficiently, and heat transfer is more efficient.

Saves Water

Water that would typically bleed off is used more, and water savings could be up to 50% or more.

ELIMINATES NEED FOR TOXIC CHEMICALS

- ***No recurring chemical expense.***
- ***No handling and storage of hazardous chemicals on site.***

REDUCES CORROSION THROUGHOUT THE FLUID SYSTEM

Reduces biocorrosion by preventing the formation of biofilm on vessel surfaces where bacteria can attack the metal. With higher concentration ratios and higher TDS, the pH will be higher and there will be much less tendency for corrosion. The long lasting Triangular Wave Treatment effect helps control corrosion throughout the fluid system.

CONTROLS ALGAE AND BACTERIA

Bacteria and algae must attach to something before they can feed and reproduce. The Triangular Wave System keeps the bacteria, algae, and their food dispersed in the water, off of surfaces, and away from their biofilm breeding ground. Biofilm forming bacteria have a life span of about two to four hours. Therefore, biofilm forming bacteria will die too, because they are unable to attach to the equipment surfaces.

SHORT PAYBACK PERIOD

The combined reduction of water and chemical costs is enough to pay for the Triangular Wave System in as little as 9-18 months.

THE PAYBACK PERIOD CAN BE FURTHER REDUCED, BECAUSE:

- ***Labor costs for maintaining the chemical systems will be reduced.***
- ***Labor costs to clean the vessel surfaces will be reduced.***
- ***Costs to replace corroded parts will be reduced.***
- ***Hidden costs associated with production shutdown will be reduced.***
- ***Equipment life will be extended.***

The Triangular Wave System requires no maintenance. There is little electrical current flow in an electromagnetic system.

LIFE CYCLE COST SAVINGS

Cost savings continue long after the payback period is over. The Triangular Wave Deposit Control System will operate effectively for many years.

COMPATIBILITY AND VERSATILITY

The Triangular Wave System is compatible with all fluid based systems - residential, light commercial, commercial, and industrial. The Triangular Wave System solenoid coils and reaction chambers can be system integrated to deal with any system or construction configurations; and still provide the same maximum fluid conditioning.



The Triangular Wave System gives owners the positive benefits of soft water without the harmful salts



Eliminate toxic chemicals & salts
No recurring chemical expenses
No handling and storage of hazardous chemicals on site
No hazardous salt contamination



Reduces the need for chlorine and get the same results with TWT "Chemical-Free" conditioning.

Triangular Wave Technologies Solves These Common Problems With Its Deposit Control & IonGuard Purification and/or Ultra-Violet Systems

The TWT® IonGuard Purification System purifies water through a process called ionization. This process utilizes a low voltage direct current [DC] to place precise and minute amounts of copper and silver ions into water systems. The TWT® IonGuard Purification System releases controlled amounts of copper/silver ions into the water to kill algae, biofilm, fungi and other microorganisms. It is well-documented fact that copper & silver ions kill algae, bacteria, viruses and even Legionnaire's Disease. These ions provide long term, nontoxic purification and prevent any recontamination. They maintain a continuous disinfection process automatically while allowing you to reduce chemical usage dramatically. This will prevent plugged water passages and severe deterioration of piping & metal surfaces.

HOW IONS ATTACK MICROBES

Ions are electrically charged atoms (An ion is merely an electronically charged atom or group of atoms. An atom acquires this charge by gaining or losing electrons. Negatively charged electrons are one of the three major subatomic particles, the others being protons, which have a positive charge, and neutrons, which have no charge). With copper-silver ionization, copper ions target algae, while silver ions kill bacteria and viruses. The ions bind with the debris and are removed in the pool filtering

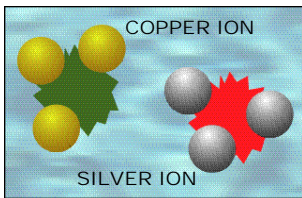

process. Ions in the Triangular Wave System are positively charged; algae, bacteria and other particles in the water are negatively charged. The positive to negative attraction allows the ions to attach to the organisms, penetrate their cell walls, and kill them. The IonGuard Purification System is an electrolytic copper/silver ion generator. The system units contain specially cast copper/silver alloy electrodes. These electrodes are mounted in a PVC housing designed for easy access.

When the system is used in conjunction with a filter, the dead bacteria with the silver ion attached will be large enough for the filter to remove. Normal filter backwashing will then remove the dead particles. The criteria for copper and silver in water are as follows: The EPA standard for drinking water is 1.0 ppm (parts per million) maximum for copper and 50 ppb (parts per billion) maximum for silver. The system is programmed so that a water test showing 0.25 ppm to 0.35 ppm copper automatically provides the proper ratio of silver. This will produce drinking water quality in any water system treated. The TWT treatment requires no chemicals in its function of controlling algae and bacteria.

A "current source" generator powers the IonGuard Purification System. Other manufacturers use "voltage source" generators to power their ionization units. In all ionization units, copper and silver ions plate off of the electrodes and enter the water. Over time, the electrodes will become smaller, and the gap between the electrodes will become larger. TWT's current source



generator will automatically compensate for the change in gap size, while voltage source generators must be manually inspected and adjusted. The current source generators in the TWT IonGuard Systems offer trouble free operation. We recommend that the IonGuard Purification System be installed downstream of a TWT Deposit Control System. The Deposit Controller will keep the IonGuard System electrodes free of scale and other deposits for more effective results. At the same time, the Deposit Control System will help eliminate scale and biofilm deposits throughout the entire water system. Without the TWT Deposit Control System in place, ionization electrodes may develop either a layer of scale or oxidation. In either case, it is necessary to periodically clean the electrodes with an acid solution. The TWT Deposit Control System eliminates the need for such periodic cleaning.

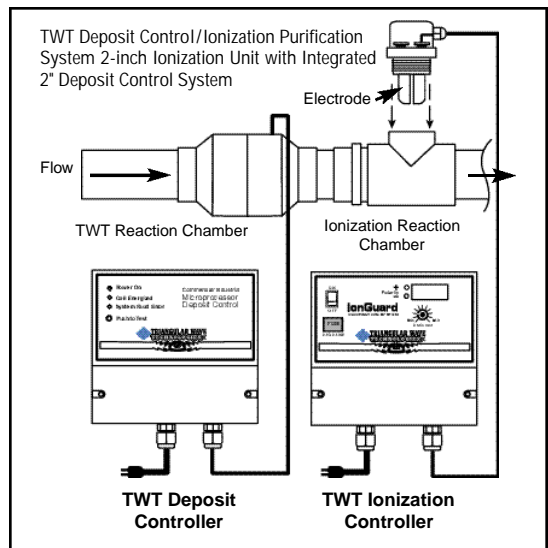
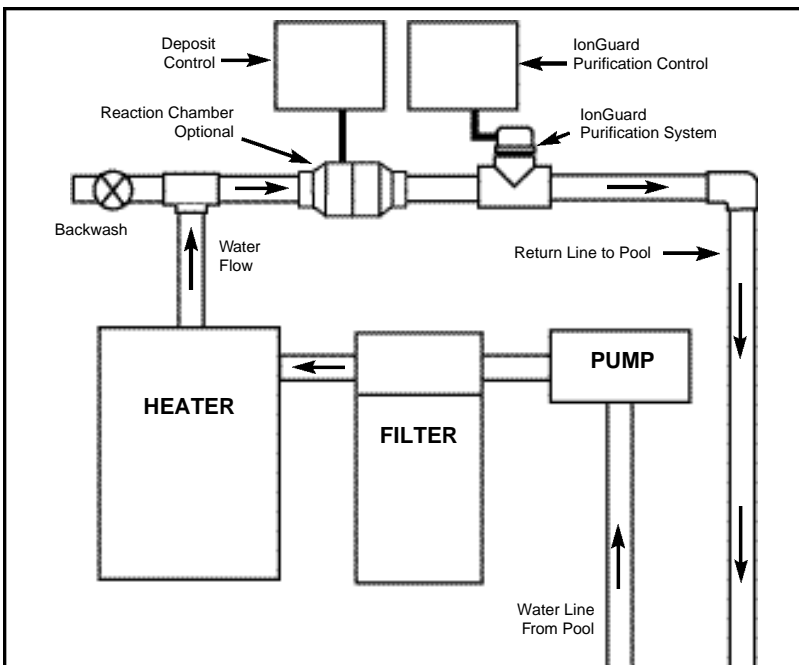

The TWT Deposit Control System will keep the IonGuard System electrodes free of scale and other deposits for more effective results. At the same time, the Deposit Control System will help eliminate scale and biofilm deposits throughout the entire water system.

Typical installation overview of pool/spa equipment room. TWT products (sizes) will vary according to pool size and volume of water. See section B5 of TWT catalog for additional information.

Triangular Wave Technologies Solves These Common Problems With Its Deposit Control & IonGuard Purification and/or Ultra-Violet Systems

UV IS AN EFFECTIVE WAY TO ELIMINATE CONTAMINANTS COMMONLY FOUND IN POOLS

Without proper disinfection, swimming pools, wading pools, water parks and water rides can cause the following symptoms on bathers:

- Burning eyes
- Itchy skin
- Swimmer's ear
- Upset stomach

In the past, the disinfection of choice for pool applications has been chlorine. However, with the use of chlorine, disinfection by-products (DBP's), such as chloramines and trihalomethanes (THMs), lead to the above discomforts for bathers. To reduce the level of DBP's, ultraviolet (UV) light systems are now being used as a supplemental disinfection method to chlorination.

CONCERNS AND EFFECTS OF CHLORINE AND CHLORAMINES

Chlorine disinfection requires additional chemicals and periodic testing to maintain the proper pH balance. But, the addition of chlorine to water lowers the pH of the water. Chlorine works best within a range of 7.2 to 7.8, outside this range, the pool bather begins to show skin and/or eye irritation. As the pH drops with additional

chlorine, another chemical, such as soda ash, is added to raise the pH. Adding more chlorine – again requiring additional chemicals to maintain the desired pH of 7.5 – created chloramines, which results in further eye irritation and respiratory problems for bathers and gives off the strong chlorine odor common at indoor pool complexes.

In addition, corrosion to metal components of the pool– ladders, handrails, and other unpainted metal surfaces is directly caused by chloramines.

ULTRAVIOLET IS A SOLUTION

To stop the vicious cycle of adding chemicals, UV is a solution. UV treatment, in addition to deposit control, will lower the amount of chlorine and other chemicals, while preventing adverse effects on the pH balance of the pool. Ultraviolet light will not only lower chemical costs, it will also reduce chloramines up to 80%, thus eliminating the strong chlorine odor.

BENEFITS OF ULTRAVIOLET IN SWIMMING POOLS

#1– Lower contaminant levels

One advantage of using UV in a pool or spa application is the level of disinfection it creates against viruses, bacteria, cysts and protozoa. The disinfection is made without affecting the taste, odor or pH balance in the pool. A properly sized uv system will disinfect the entire volume of a

pool in six hours or less with a turnover rate at a minimum of three times a day. The UV system is a constant disinfection so delivering a safe chemical-free barrier against unfound fecal accidents in a fraction of the time required for chlorine.

#2– Removal of chloramines

An additional advantage of using UV light in a pool application is the reduction of chloramines. The interaction between free chlorine and organic matter forms chloramines. It is the concentration where the chlorine odor and bather systems begin. Ultraviolet light photosynthesizes chloramines, breaking them down into salts.

HOW WELL DOES ULTRAVIOLET LIGHT REDUCE CHLORAMINES?

UV reduces chloramines up to 85%. Such a reduction lessens the chlorine odor and lowers the corrosion rate on the system allows for the reduction of chlorine use by over 50%, cutting chemical costs in half for both chlorine and soda ash for disinfection and pH adjustments.

The combination of the Ultra-Violet system, TWT Deposit Control system and the IonGuard Ionization system will eliminate the need for chemicals

PLACEMENT OF A UV SYSTEM

The placement of a UV system is shown (see illustration below).

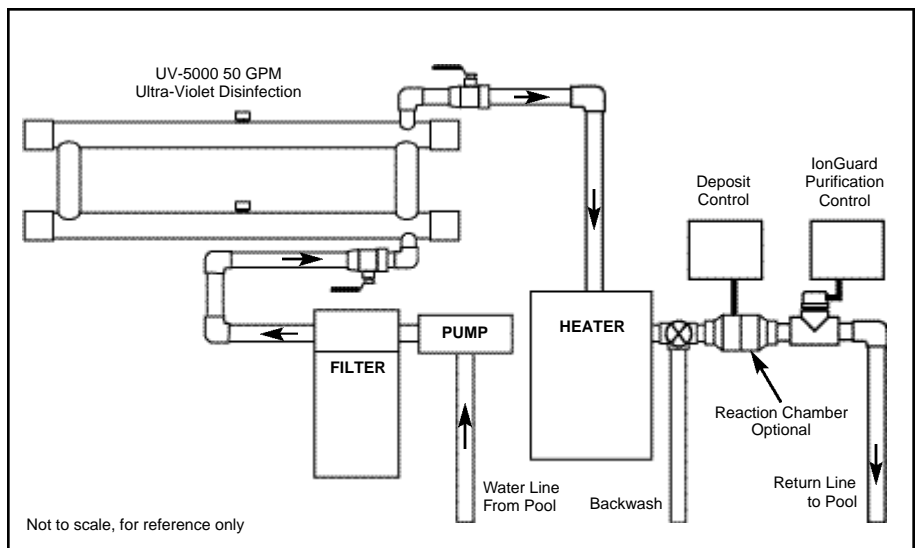
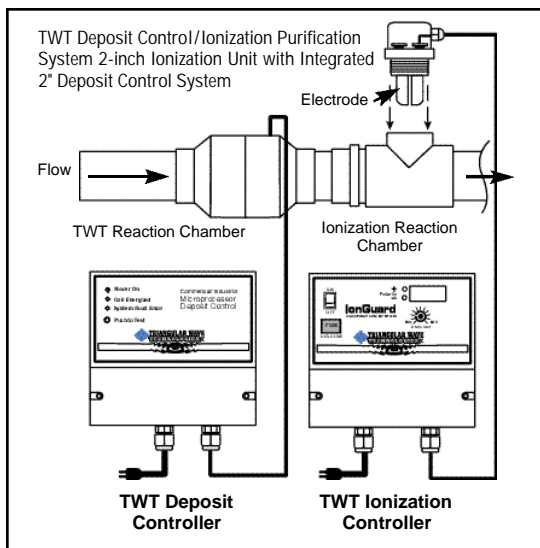

Typical installation overview of pool/spa equipment room. TWT products (sizes) will vary according to pool size and volume of water. See sections B3 and B5 of TWT catalog for additional information.

Please Note:

System design, and system component assembly can vary based on TWT engineering review, water conditions, application, and/or customer specific needs

**1. DEPOSIT CONTROL
 (CHEMICAL-FREE)**

TWT® Patented Deposit Control Technology
 The basic component in the TWT systems is the deposit controller. It is comprised of a

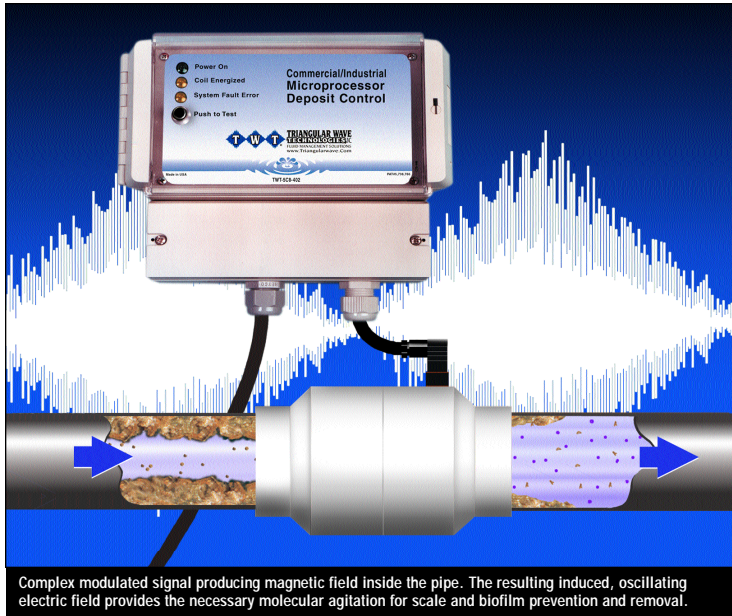

microprocessor, solenoid coil wrap and/or a reaction chamber. The microprocessor is a patented controller that functions like a computer to relay a continuous electrical power supply to the solenoid coil and/or reaction chamber. The reaction chamber is plumbed into the main water in-take line and/or just before each piece of vital processing equipment, and provides a factory wrapped wire coil forming a solenoid.

The solenoid conveys the triangular wave signal at the appropriate power level (as allowed by the model chosen) to the water passing through the chamber. This signal constantly changes the polarity, frequency, and amplitude of the current entering the water. This triangular wave treatment produces several benefits. It increases the capability of the water to hydrate scale ions and other colloidal particles. In effect, the surface charge of the hydrogen molecules is enhanced and the water is made "wetter". This "hydrated" water can dissolve unwanted particles, suspend them in solution, and allow them to be easily filtered out or flushed from the system. Accordingly, the and biological particles that cause scale, deposits, and corrosion are dissolved and washed away. This means that the breeding environments for bacteria, such as bio-film and corrosion, are eliminated.

The agitation created in the reaction chamber also disrupts the conditions essential for the normal reproduction of bacteria and they die, thus allowing them to be harmlessly flushed out of the system. If left

untreated, scale build-up inside the reaction chamber and on the quartz sleeve containing the UV lamps may rapidly diminish the UV disinfection effectiveness by reducing the amount of UV light which is absorbed into the water stream. The

TWT Deposit Control System will further condition the filtered water stream so as to prevent this scale-build-up inside the UV reaction chamber, helping to maintain maximum UV life cycle and penetration into the water stream.

TWT REACTION CHAMBER:

The TWT Reaction Chamber is part of the patented TWT Deposit Control Technology. The Reaction Chamber provides a chamber through which the

water flows and is exposed to the triangular wave signal that lies at the heart of the deposit control technology. As the fluid passes through, it is treated and then carries that treatment downstream, to condition the rest of the plumbing system, non-chemically and reliably.

2. DISINFECTION/PURIFICATION:

Ultra-Violet:

The UV disinfection technology used in the system provides safe, potable drinking water, free of disease-causing pathogens. As water passes through the UV chamber, UV light will attack and render harmless any bacterial, viral or spore contamination present in the treated water. "High intensity UV light destroys these contaminants with a 99.9% kill rate" The output water is thus disinfected and offers exceptionally high quality for human consumption.

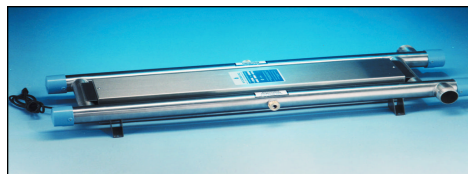

UV-5000

IONIZATION—for bacteria, algae, fungus control in Pools & Spas

IONGUARD PURIFICATION SYSTEM:

The IonGuard Purification System is an electrolytic copper / silver ion generator. The system units contain specially cast copper/ silver alloy electrodes. These electrodes

are mounted in a housing designed for easy access (Pool Environments). The IonGuard Purification System purifies water through a process called ionization. This process utilizes a low voltage direct current [DC] to place precise and minute amounts of copper and silver ions into water systems. Copper ions kill algae and silver ions kill bacteria (integrate with TWT deposit control technology for enhanced results).



Silver & Copper Electrodes



Electrode Housing Unit

END-TO-END FLUID TREATMENT AND CONDITIONING

TWT, Inc. offers a full range of products & systems designed to address fluid problems wherever fluid flows. From patented deposit control technology to pre and post filtration needs, ionization, disinfection, and ultraviolet purification treatment and conditioning. Components and subsystems chosen from across the range of treatment methods can be combined in different configurations to provide custom solutions specific to any industry, site or application. TWT has the versatile, efficient, cost-effective methods to solve your fluid management problems end to end.

For additional information: Visit Triangular Wave Technologies, Inc. Comprehensive Website. The Valuable Technical Resource For All Involved In Water And Fluid Management. WWW.TRIANGULARWAVE.COM

Control Scale Deposits/Bacteria Corrosion Algae /Colloids In Your pools & spas. Eliminate the biofilm that serves as a breeding ground for disease - causing bacteria, collecting in your pipes, tubing and equipment.

DON'T WAIT...contact us today (info@Triangularwave.com) for the Dealer/Distributor near you and/or for information on what TWT system will meet your specific application needs!

NO MATTER HOW TOUGH THE JOB...TWT® IS THE SOLUTION