



# BRS<sup>2</sup> BACTERIAL REDUCTION SYSTEM

*Not Just A System, It's The Solution*

Central System for Multiple Injector Lines

## Technologically Advanced Fluid Treatment Method for the Meat, Poultry and Related Processing Industries

*“THE COMPETITIVE EDGE”*

**Filtration • Deposit Control Technology • UV Disinfection & Purification**

**COMBINED FOR MAXIMUM EFFECTIVENESS**

*The following features make the BRS/2 particularly effective in treating brine:*

*The BRS/2 bacterial reduction system combines several unique technologies to achieve a very high bacterial kill rate, at least 3 logs for common contaminants.*

**FILTERING:** The BRS/2 provides two-stage filtering. This helps clarify the brine. The cleaner the brine, the more effective the treatment system will be.

**DEPOSIT CONTROL:** De-calcifies water, making it “wetter”. Less chance of mineral build-up on UV lamps.

**Dual QUATTRA 50 UV STATIONS:** The double Quattra 4 lamp stations will achieve a 3 log reduction on a single pass. The lamps have pneumatic wipers



to keep them clean. The system is designed for a double pass on all brine. A proprietary reaction chamber design allows for maximum exposure of the brine to the UV light during the treatment process, yielding better bacterial kill.

**CENTRAL SYSTEM:** This system can treat up to 1500 gallons per hour. This can feed up to 4 injection lines for fresh marination.

Distributed by

**NU-MEAT TECHNOLOGY, INC.**

601 Hadley Road • P.O. Box 897 • South Plainfield, NJ 07080 • 908-754-3400 • FAX 908-754-3401  
www.nu-meat.com • email: sales@nu-meat.com



# BRS<sup>2</sup> BACTERIAL REDUCTION SYSTEM



## *Not Just A System, It's The Solution* Point-Of-Use – Central System for Multiple Injector Lines

TWT Deposit Control Technology • Double Quattra 50 Ultraviolet Disinfection & Purification  
• 2-Stage Filtration • Multi Process – Combined for Maximum Effectiveness

- The system process is guaranteed to achieve a minimum three (3) log reduction for common bacterial contaminants. The recirculating ability of the system will guarantee an enhanced kill rate.
- Multiple technologies, including Filtration, TWT Patented Deposit Control Technology, Ultraviolet and Disinfection & Purification, are combined for maximum effectiveness.
- BRS/2 system, able to treat up to 1500 gallons of brine per hour.
- All brine, both incoming and recirculated, is passed through the system, assuring only “treated” brine is injected into the meat/ poultry.
- The BRS/2 bacterial reduction system is ruggedly constructed for exceptional performance. The rugged self-contained design of this system ensures that the system will enjoy a long and reliable life cycle when properly cared for.
- Easy to follow care, maintenance & operation manual. Other basic informational labels are affixed to the system (system requires minimal maintenance).
- The BRS/2 system guarantees a reduced bacterial load in the brine solution; this ensures a cleaner, safer product for processing & consumption.
- Self Contained Unit
- Enhance Food Safety Efforts by Controlling Pathogens and Spoilage Organisms Which May Enter Brine
- Enhance Shelf Life
- High Quality Final Output
- No Chemicals Used
- Environmentally Friendly
- Insures That Safe Products are Delivered to Consumers
- Cost Effective and Pays for Itself

**\$2.7 Billion, the cost of E.Coli 0157:H7**

**Recalls:**

Meat & Poultry Journal  
Feb 2003

**Rising Insurance Costs:**

Meat & Poultry Journal  
March 2003

Distributed by

**NU-MEAT TECHNOLOGY, INC.**

601 Hadley Road • P.O. Box 897 • South Plainfield, NJ 07080 • 908-754-3400 • FAX 908-754-3401  
www.nu-meat.com • email: sales@nu-meat.com



# B.R.S<sup>2</sup> BACTERIAL REDUCTION SYSTEM

**Not Just A System, It's The Solution**

**The BRS/2 is Able To Treat Up To 1500 Gallons Per Hour-High Efficiency Fluid Treatment System**  
System is a compact, self-contained St/St unit, for the treatment & conditioning of water/brine.



**Point-Of-Use-Central System for Multiple Injector Lines**

2" inch Stainless Steel piping throughout/Quick connect couplings at various points in system • BRS/2 Flow Schematic & Treatment Process: Blue=Flow End-to-End

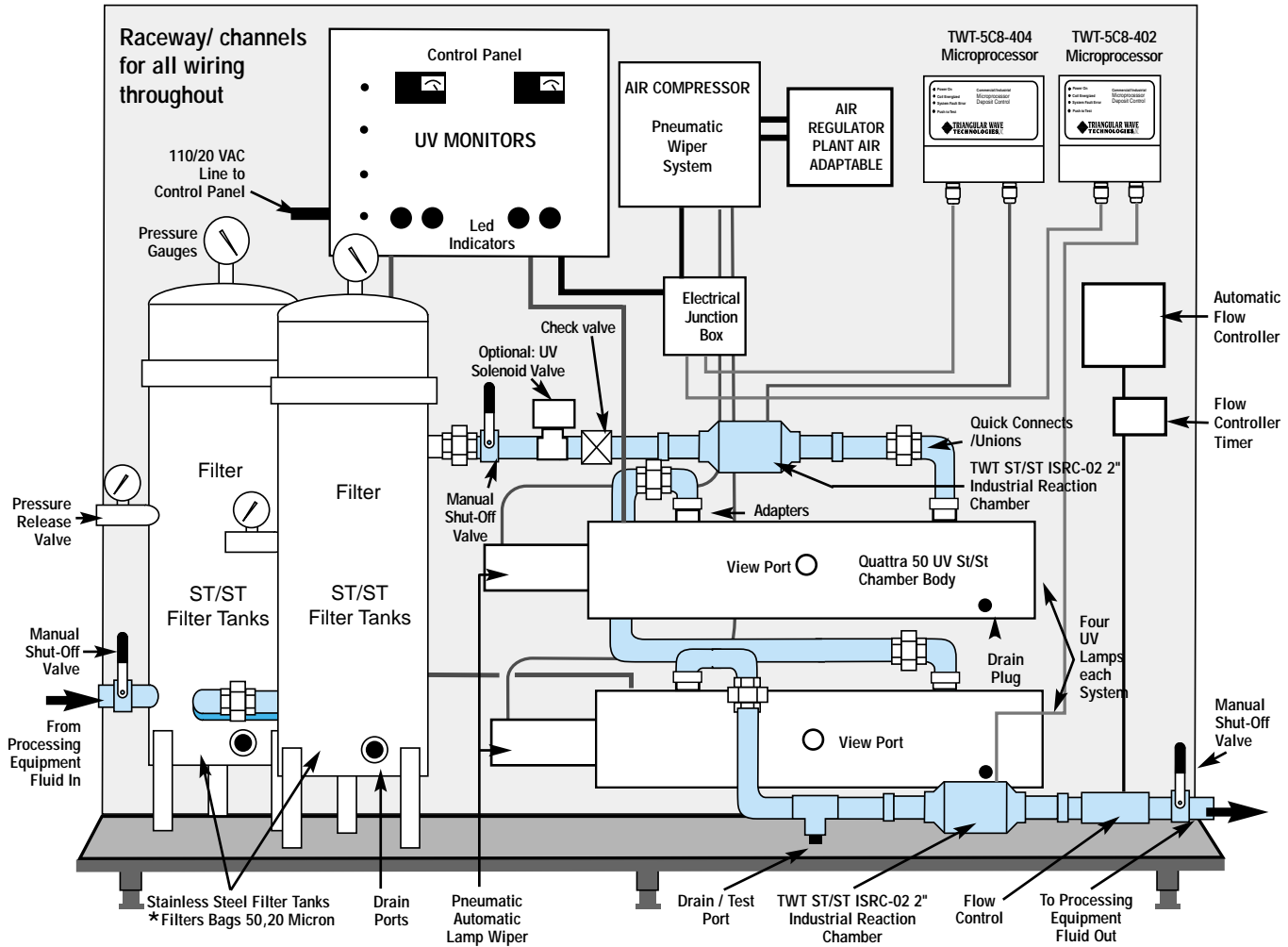

System engineering design, weight, size and system component assembly may vary based on TWT engineering review, application, industry and/or customer specific needs

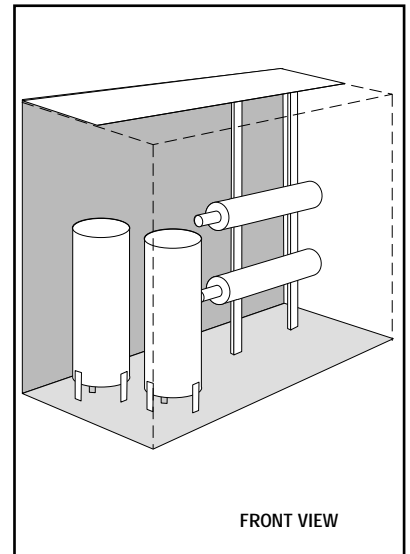
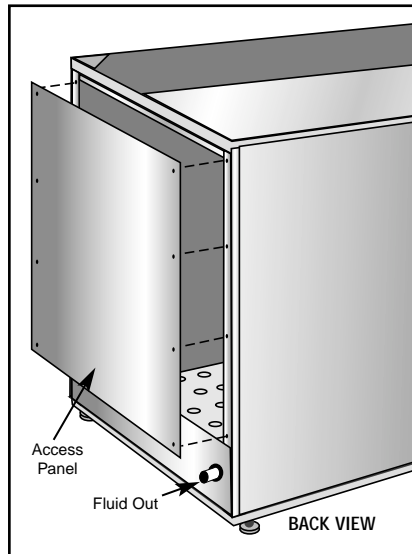
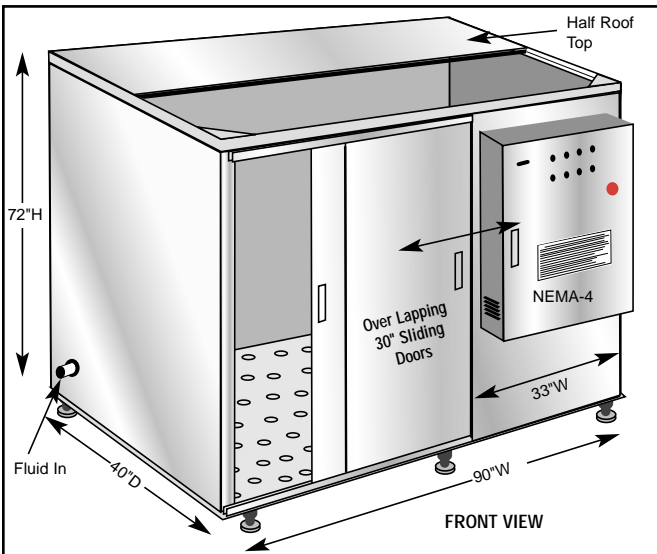

Distributed by  
**NU-MEAT TECHNOLOGY, INC.**

# BRS/2 Factory Assembled & Enclosed Unit Able to Treat Up To 1500 Gallons Per Hour—High Efficiency Fluid Treatment System

**This fluid management system is a compact, self-contained St/St unit for the treatment & conditioning of water/brine & conditioning of water/brine**

## Process Overview

The system incorporates Two Stage Filtration, TWT® Deposit Control Technology, Quattra 50 UV disinfection/purification and other components as illustrated for treatment of the water/brine solution. The system is designed to integrate with existing treatment processes and equipment configurations.

## Basic Systems Operation/System Detail:

The solution will pass through a 2 stage filtration process. Low-cost bag type filters are used here to keep operating costs to a minimum and for simplicity of change-out.

The system will then process the filtered fluid through the TWT reaction chamber to treat and condition the fluid, (within the deposit control system) then through the Quattra 50 UV to provide disinfection/purification to the fluid stream. The solution will then pass through another TWT reaction chamber (within the deposit control system) to enhance the disinfected fluid that is sent to and through other processing equipment (this provides end-to-end fluid treatment and conditioning).

## Filtration:

Filters are designed to trap various kinds of debris, dirt, and organic particles that will otherwise enter your equipment and/or plumbing system, restrict flow and create a breeding ground for bacteria. Filtration is the first line of defense. The first step in achieving clean water/brine is to install a filtration device that effectively removes particulate matter and similar debris. Filter bags/medium used in staged filter housings are configured as illustrated. If fluid conditions require smaller micronic particle trapping for enhanced results, filter bags for housings are available in various micronic sizes (providing flexibility & adaptability to meet the needs of all fluid conditions & applications).

## TWT Patented Deposit Control Technology:

The basic component in the TWT® systems is the deposit controller. The microprocessor is a patented controller that functions like a computer to relay a continuous electrical power supply to the solenoid coil reaction chamber. The reaction chamber is plumbed into the fluid line just before each piece of vital processing equipment, and provides a factory-wrapped wire coil forming a solenoid. The solenoid conveys the triangular wave signal at the appropriate power level (as allowed by the model chosen) to the fluid passing through the chamber.

This signal constantly changes the polarity, frequency, and amplitude of the current entering the fluid. This triangular wave treatment produces several benefits. **It increases the capability of the fluid to hydrate scale ions and other colloidal particles.** In effect, the surface charge of the hydrogen molecules is enhanced and the fluid is made “wetter”. This “hydrated” fluid can dissolve unwanted particles, suspend them in solution, and allow them to be easily filtered out or flushed from the system. Accordingly, the mineral and biological particles that cause scale, deposits, and corrosion are dissolved and washed away.

This means that the breeding environments for bacteria, such as bio-film and corrosion, are eliminated. The agitation created in the reaction chamber also disrupts the conditions essential for the normal reproduction of bacteria and they die. **If left untreated, scale build-up inside the reaction chamber and on the quartz sleeve containing the UV lamps may rapidly diminish the UV disinfection effectiveness by reducing the amount of UV light which is absorbed into the fluid stream.** The TWT Deposit Control System will further condition the treated fluid stream so as to prevent this scale-build-up inside the UV reaction chamber, helping to maintain maximum UV life cycle and penetration into the fluid stream.

## Ultraviolet Disinfection

**The UV disinfection technology is used in the system to provide safe fluids, free of disease-causing pathogens.** As fluids pass through the UV chamber, UV light will attack and render harmless any bacterial, viral or spore contamination present in the treated fluid. High intensity UV light destroys these contaminants. The output fluid is thus disinfected and offers exceptionally high quality fluid for processing.

The Quattra 50 UV has an integrated pneumatic wiper system to maintain lamp efficiency, and a proprietary UV reaction chamber designed to increase the dwell time inside the chamber. The system is engineered and designed to provide a very high UV dose via extended dwell time at multiple flow rates.

---

## Distributed by:

Nu-Meat Technology, Inc. • 601 Hadley Road • P.O. Box 897  
South Plainfield, NJ 07080 • 908-754-3400 • FAX 908-754-3401  
www.nu-meat.com • email: sales@nu-meat.com

## Product TWT-BRS/2

**Utilities:** Approx. 90"W x 72"H x 40"D

**Weight:** 0000 lbs.

**ELEC:** 1 Phase 120 Volts 20 Amps

**Warranty:** 1 year parts and labor for defective parts or workmanship on mechanical components – 90 days for electrical components

**Delivery:** 6-10 weeks (after clarification of all technical details)

**Price \$** \_\_\_\_\_ – Does not include piping, pumps, floats, valves etc. to and from system. Includes installation supervision and training

**FOB:** South Plainfield, NJ USA or Company Warehouse

**Payment Terms:** 50% with purchase order, 40% on delivery, 10% thirty (30) days after delivery

*Note: We recommend that an initial supply of replacement products e.g., replacement filter bags, UV lamps etc. be stored at owners facility at all times, that will insure uninterrupted service and treatment.*

*Installation: Must have enough room on all sides for filter and UV replacement & maintenance*

*Pumps, piping, fittings, valves, and other material needed to and from system owners responsibility*